

# UP Circulator technical spec

## UP 循环泵技术规格书

### UPS32-100 180

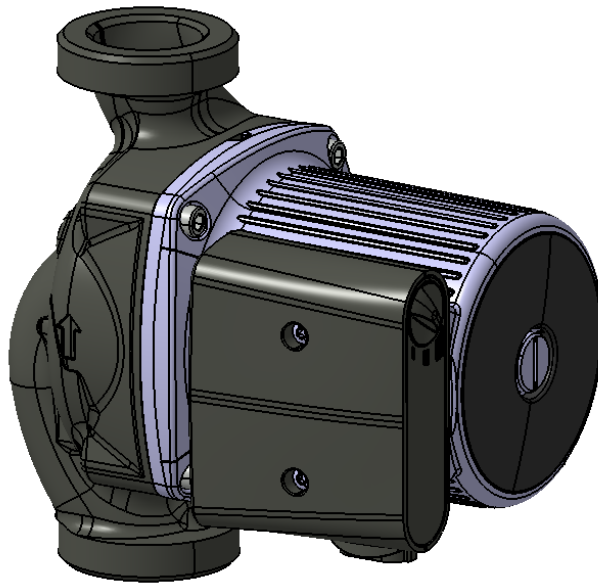

Company/单位名称: Grundfos/格兰富水泵

Description/产品名称: UPS32-100 180 1x230V 50Hz 9h

Product no/产品料号: 92605356

Customer no/客户编码: \_\_\_\_\_

#### Version control/版本控制

Version/版本	Issued date/发行时间	Released by/发行人	Notes/备注
1	2021/06/25	GCHKLI	

---

# Content/目录

1. Application 水泵应用.....	2
2. Technical data 技术数据 .....	2
2.1 Structure 结构 .....	2
2.2 Type Key 型号说明.....	2
2.3 Material specification 材质说明 .....	3
2.4 Pumped liquid 泵送液体.....	4
2.5 Ambient and liquid temperature 环境与液体温度 .....	4
2.6 Max working pressure and inlet pressure 最高系统压力和进口压力 .....	4
2.7 Technical data 技术参数.....	5
2.8 Performance curve 性能曲线图.....	6
2.9 Dimensions 产品外形及尺寸图.....	7
2.10 Explode view 产品爆炸图 .....	8
3. Design and Inspection standard 设计和检测标准.....	9
4. Quality and certification 质量及证书 .....	9
5. Installation and maintenance 安装及维护 .....	9
6. Fault finding 故障原因及解决方法.....	10

## 1. Application 水泵应用

UPS pumps are primarily suitable for circulation of liquid in below systems:

- Central heating systems
- District heating systems
- Hot water service system

The pump has 3-step speed selector.

格兰富UPS 180系列循环水泵系列主要应用于集中,区域供暖系统和生活热水系统。该水泵能在三档转速下运行。

## 2. Technical data 技术数据

### 2.1 Structure 结构

The pump is of the canned rotor type, pump and motor form an integral unit without shaft seal and with only two gaskets for sealing. The bearings are lubricated by the pumped liquid. The pump is characterized by:

- Ceramic shaft and radial bearings.
- Carbon axial bearing.
- Stainless steel rotor can and bearing plate.
- Corrosion-resistant impeller, Composite, PES/PP.
- Pump housing in cathodolysis treated cast iron and enamel process inside

UPS 180 泵系列循环水泵属于屏蔽湿转子泵，即：水泵与电机形成一个整体单元，水泵无轴封、只含两个密封垫圈。轴承由泵送液体润滑。

水泵的结构有如下特征：

- 陶瓷轴和径向轴承；
- 碳质推力轴承；
- 不锈钢转子罩和轴承挡板；
- 叶轮采用耐腐蚀材质制成；
- 水泵底座用电泳处理的铸铁制成并且内部进行搪瓷工艺处理。

## 2.2 Type Key 型号说明

Example 示例	UPS	32	-100	180	1x230V 50Hz	9H
Pump type 水泵类型 UP: Single speed pump 单速泵 UPS: 2 or 3 speed pump 2或3速泵						
Inlet/outlet diameter 吸水口/排水口公称直径(DN)[mm]						
Max head 最大扬程[dm]						
Pump housing type 泵壳型号 N: Stainless steel						
Input power 输入电压, 频率						
Position of terminal box 接线盒位置						

## 2.3 Material specification 材质说明

### 材料规格

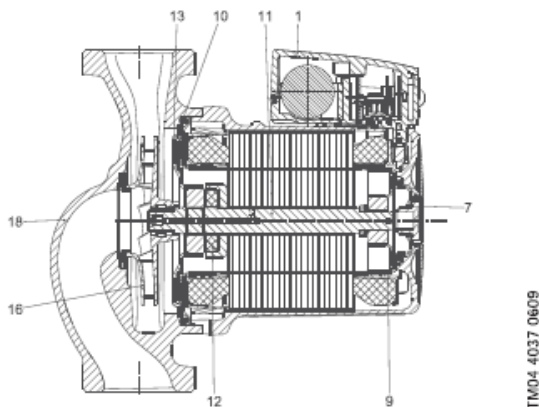

Pos 位置号	Component 元件	Material 材质	EN	AISI/ASTM
1	Terminal box 接线盒	Composite 复合材料		
7,10	Gasket 垫片	EPDM 橡胶		
9	Rotor can 转子罩	Stainless steel 不锈钢	1.4301	304
	Radial bearing 径向轴承	Ceramics 陶瓷		
11	Shaft 轴	Ceramics 陶瓷		
	Thrust bearing 推力轴承	Carbon 碳		
12	Thrust bearing retainer 推力轴承护圈	EPDM 橡胶		
13	Bearing plate 轴承底板	Stainless steel 不锈钢	1.4301	304
16	Impeller 叶轮	Composite 复合材料		
18	Pump housing 水泵壳体	Cast iron 铸铁	EN-JL 1020	A48-25B

Notes: Product picture may differ from actual product, please refer item 2.9 for 2D drawing and real pump.

注: 产品图片可能与实际不符, 请参考 2.9 二维图及实际样品。

## 2.4 Pumped liquid 泵送液体

UP, UPS pumps are suitable for pumping the following liquids:

- Clean, thin, non-aggressive and non-explosive liquids without solid particles or fibers
- In heating systems, the water should meet the requirements of accepted standards on water quality, for example the German standard VDI 2035-1
- Softened water: in domestic hot-water systems, the circulator pump should be used only for water with a degree of hardness lower than approximately 17°Dh.

根据水泵类型, UPS 循环水泵主要应用于如下液体:

- 洁净, 低粘度, 无腐蚀, 非易爆液体, 不含固体颗粒或纤维
- 在供暖系统中, 水质应符合公认的供暖系统水质要求, 如德标: VDI2035-1
- 软化水: 在家用热水系统中, 循环泵适用于水质硬度低于大约17°Dh的水。

## 2.5 Ambient and liquid temperature 环境与液体温度

Liquid temperature range 液体温度范围: -25°C – 110°C

Ambient temperature range 环境温度范围: 2°C – 40°C, humidity 相对湿度 <95%。

The pump is designed with double-coated winding and the stator housing has drain holes, it is suitable in colder water system which may create condense water inside the stator. 水泵电机线圈双层保护, 定子外壳拥有排水孔可以排出可能产生的冷凝水。

## 2.6 Max working pressure and inlet pressure 最高系统压力和进口压力

Maximum working pressure 水泵最大工作压力: 10 bar

To avoid cavitation noise and damage to the pump bearings, the following minimum pressures are required at the pump suction port:

为避免气蚀产生噪音和损坏水泵轴承，水泵的进口处需维持最小进口压力：

Liquid temperature 液体温度	≤85°C	90°C	110°C
Min. inlet pressure 进口压力	0.5m head 0.049 bar	2.8m head 0.27 bar	11.0 m head 1.08 bar

## 2.7 Technical data 技术参数

Electrical data/电气参数：

Rated voltage/额定电压： 1x230V

Mains frequency/电源频率： 50Hz

Max. power input/最大转速时输入功率： 344W

Power input in speed 2/转速2时输入功率： 340W

Power input in speed 1/最小转速时输入功率： 278W

Current in speed 3/最大转速时电流： 1.50A

Current in speed 2/转速2时电流： 1.51A

Current in speed 1/最小转速时电流： 1.27A

Capacitor size – run/电容： 9.5μF

Enclosure class (IEC 34-5)/ 产品的防护等级： IPX4D

Insulation class (IEC 85)/产品的绝缘等级： Class H

Noise level in normal operating range/

泵在正常带液体运行状态下，噪音等级 ≤43 dB(A)

## 2.8 Performance curve 性能曲线图

92605356: UPS32-80 180 1x230V 50Hz

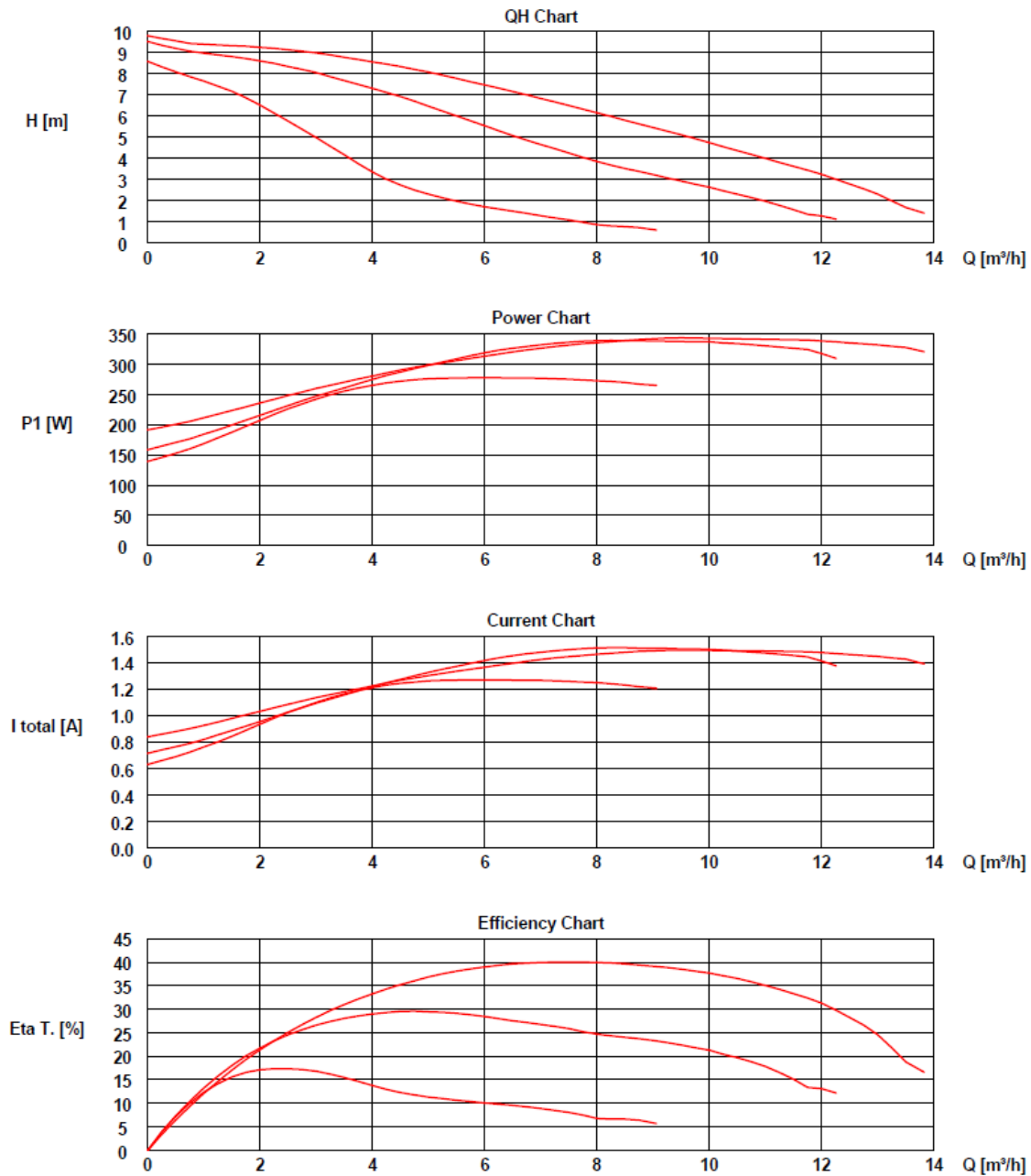

Performance test based on standard ISO 9906 with pre-pressure 2.0bar and liquid temperature 20°C. /性能测试依标准 ISO 9906，系统初始压力 2.0bar，液体温度 20°C .

Dimensions 产品外形及尺寸图

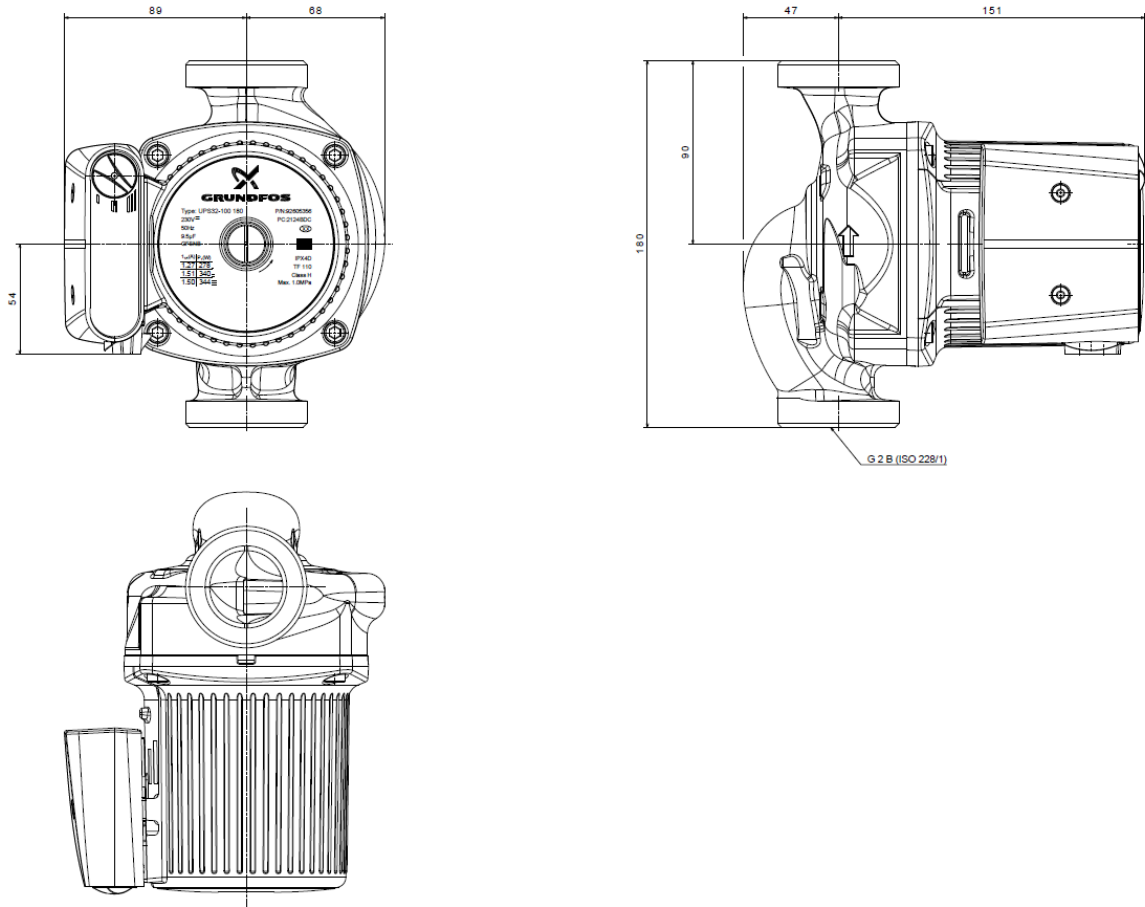

Noted 备注: with power connection “Alpha 2 plug” set. 附 Alpha 2 电源接头. 参考 “Alpha 2 plug” 了解如何使用该电源接头。



2.9 Explode view 产品爆炸图

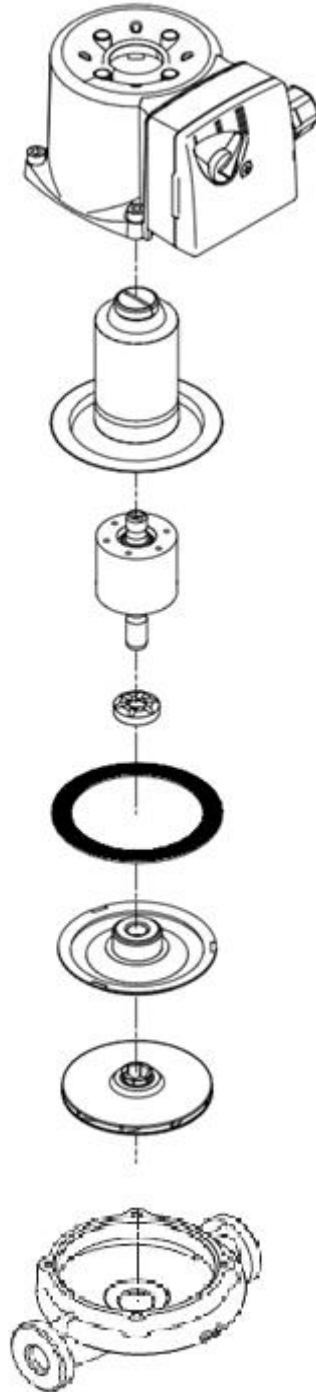

Notes: Product picture may differ from actual product, please refer item 2.9 for 2D drawing and real pump. /产品图片可能与实际不符，请参考 2.9 二维图及实际样品。

### **3. Design and Inspection standard 设计和检测标准**

The UPS pump follows below EEC standard/格兰富水泵有限公司UP系列水泵符合以下EEC标准的要求:

The motor is a 2 pole asynchronous squirrel-cage motor in conformity with the Electromagnetic Compatibility Directive to the standards EN 61000-6-2 and EN 61000-6-3./水泵电机为2极，异步鼠笼式电机，符合EMC指令标准。测试标准：EN61000-6-2和EN61000-6-3

The terminal box and the motor-pump unit have been wet-tested in conformity with the Low Voltage Directive to the standards EN 60335-1 and EN 60335-2-51. 接线盒与电机-水泵机组均已通过湿式测试。

测试标准：EN60335-1与EN60335-2-51

### **4. Quality and certification 质量及证书**

In accordance with the ISO9001 and ISO14000 standard, GRUNDFOS is established and obtained ISO9001 and ISO1400 quality certification system certification./格兰富 UPS 循环水泵依照 ISO9001 和 ISO14000 标准建立并获得了 ISO9001 和 ISO1400 质量认证体系认证证书。

Obtain OHSAS18001 occupational health and safety management system certification. /获得OHSAS18001职业健康安全管理体系认证。

### **5. Installation and maintenance 安装及维护**

The pump must be installed with the motor shaft positioned horizontally. If the pump has an air vent, the air vent must point upwards. When start-up the pump, please remove the air vent screw from motor for air venting.

Under the condition of correct installation and correct use of the pump is maintenance-free. For detail, please refer “UP, UPS series 100 I&O” ./ 安装水泵时必须与电机轴保持水平。在启动时，移除电机上方的螺栓进行

排气。在正确的安装并正确的使用情况下，水泵是不需维护的。具体参考“UP 泵安装说明书”。

## 6. Fault finding 故障原因及解决方法

### 故障查询表:

Fault 故障	Cause 原因	Remedy 解决方法
The pump is not running. 水泵不启动	No electrical supply. 供电故障	Check the electrical circuit. 检查熔丝，同时电源连接有可能松动
	Capacitor problem. 电容器故障	Replace capacitor. 更换电容器
	Pump is blocking by fibre or other. 水泵由于纤维缠绕而堵转	Run the pump to max speed short time, or use screwdriver to rotate the rotor. 短时间切换到最大速度运转或在轴端缝中插入螺丝刀转动转子
	Pump is dirty inside. 水泵内不清洁	Clean the pump. 清洗水泵内部
Noise system. 系统有噪音	Too high flow set. 水泵流量设置太高	Set the pump to lower speed. 切换到低转速
	With air inside the system. 系统中有气	System air venting. 系统排气
Noise pump. 水泵有噪音	With air inside the pump. 水泵中有气	Pump air venting. 水泵排气
	Too low inlet pressure. 进口压力太低	Increase the inlet pressure or check the amount of air in the pressure tank (if system has it). 增高进口压力或检查膨胀水箱中的空气量（如果安装的话）